



Riqualificazione Voltini Ferroviari di Via Buranello

PIANO NAZIONALE DI RIPRESA E RESILIENZA (P.N.R.R.)
MISSIONE 5 COMPONENTE 2 MISURA 2.2 - P.U.I



Il contesto urbano

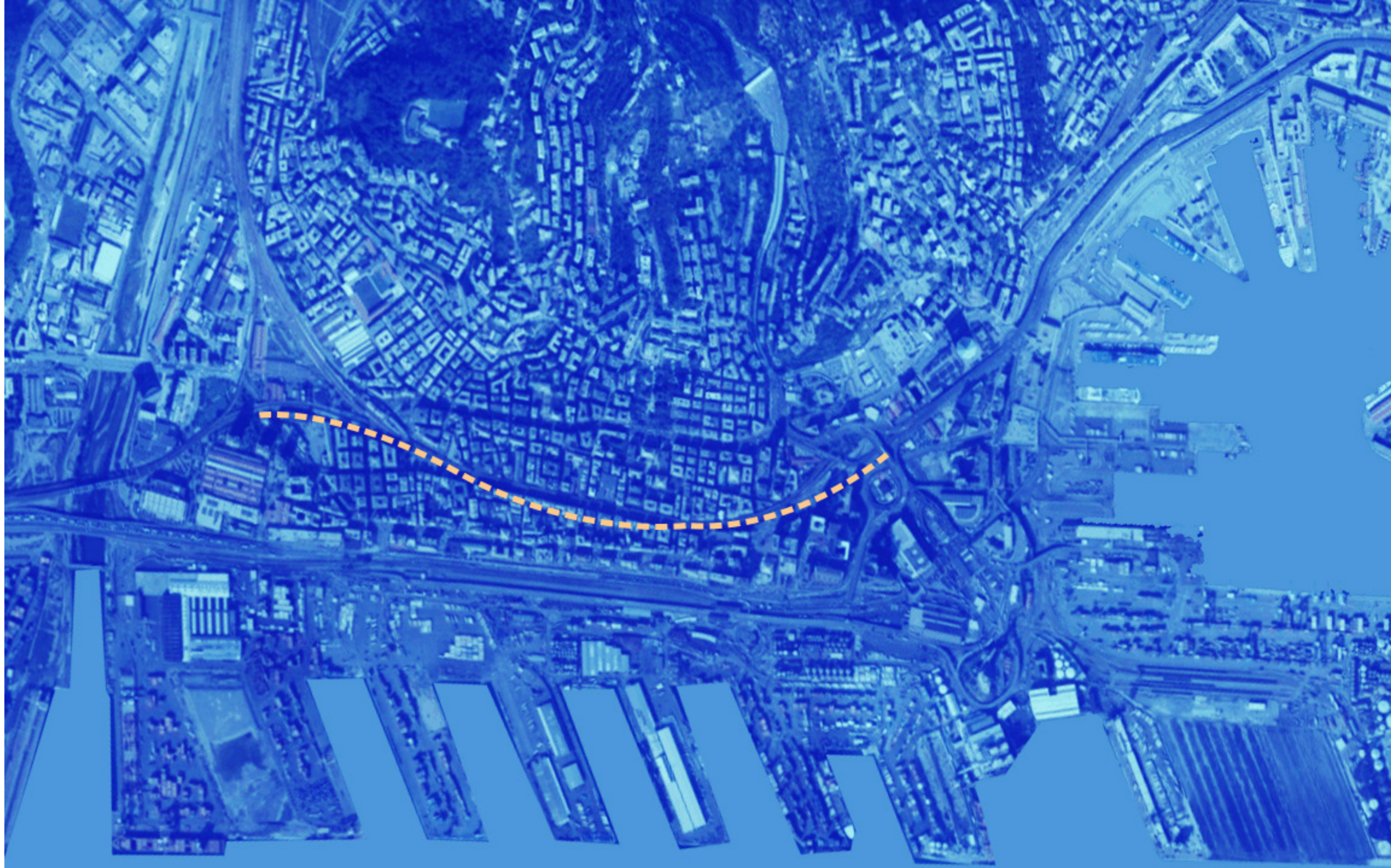

----- Riqualificazione di Via Buranello e limitrofe



I voltini di Via Buranello

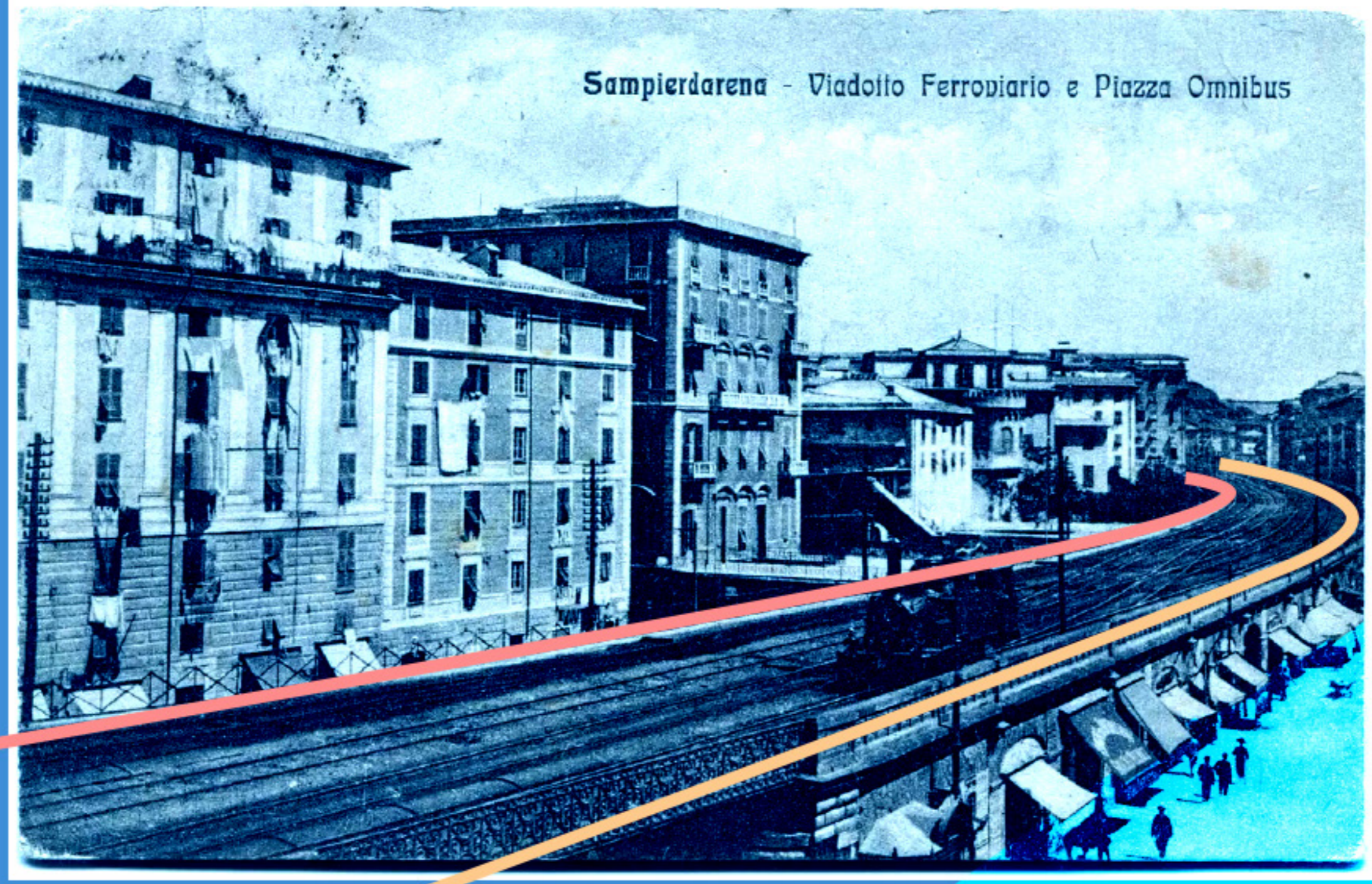

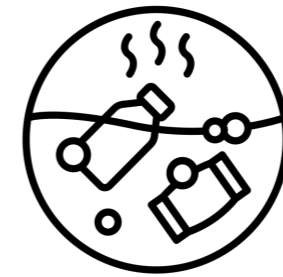
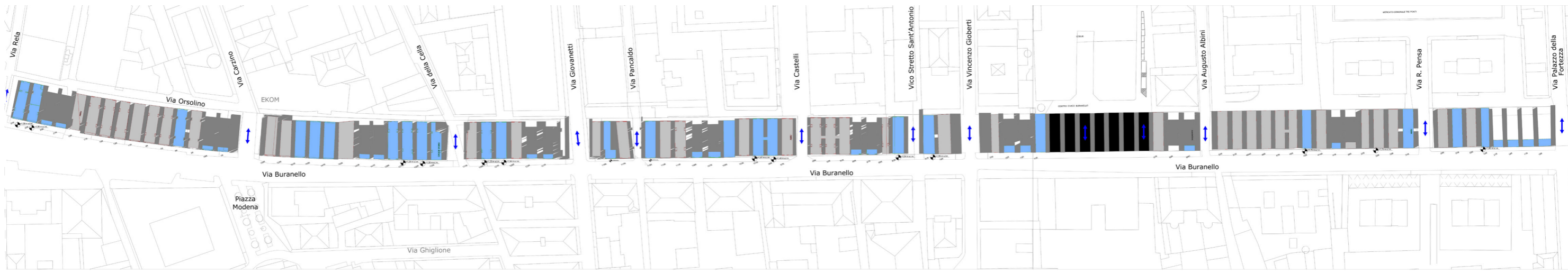

Stato di degrado e insalubrità

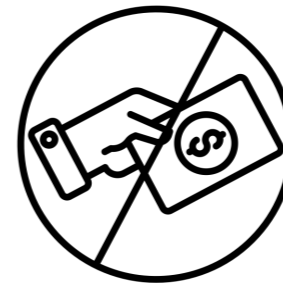

Inutilizzo di spazi pubblici



Spazi non presidiati

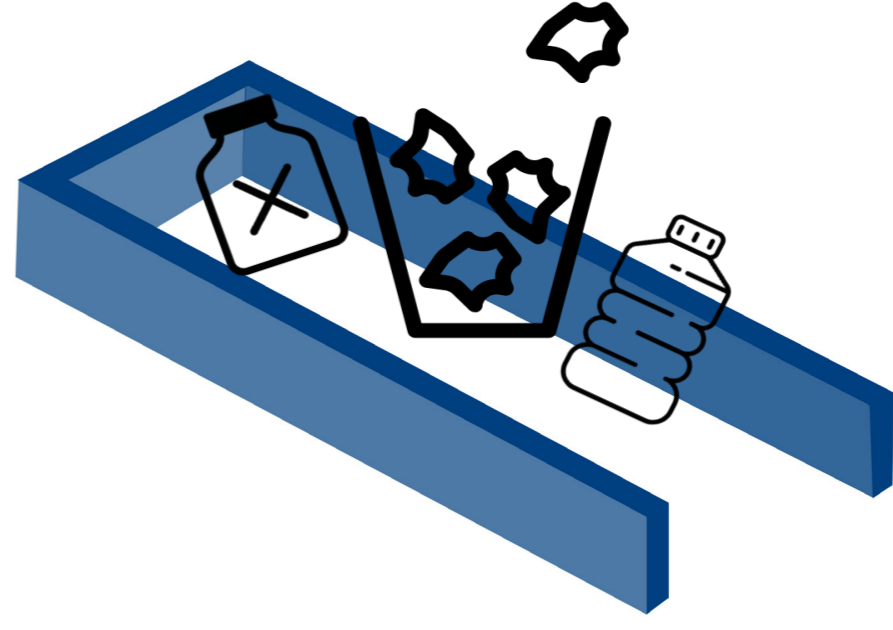
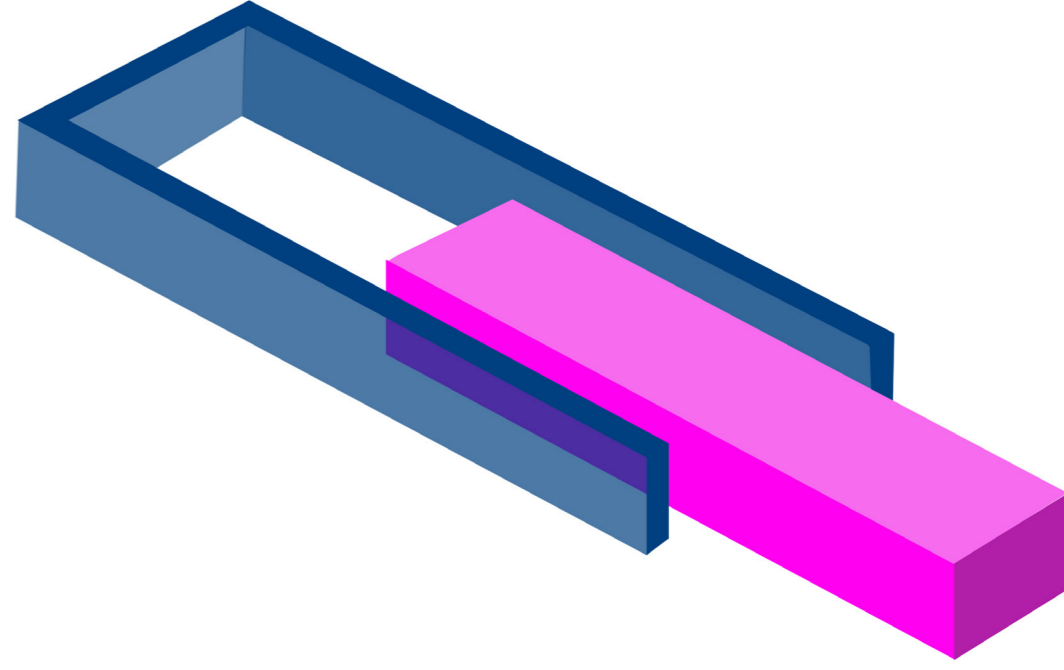

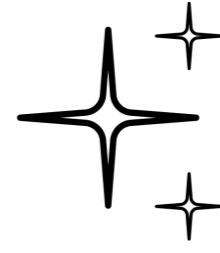
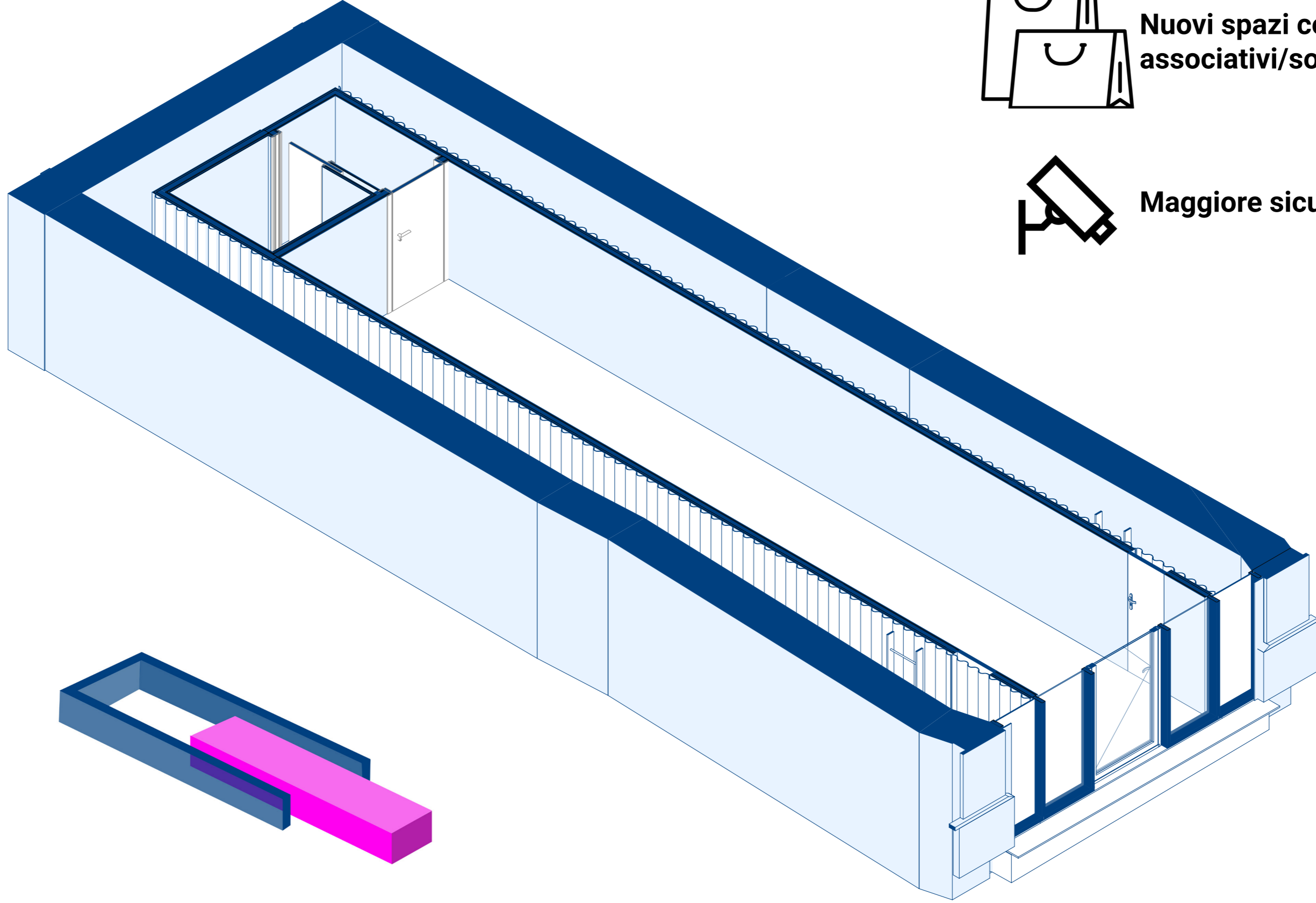

Nuovo volto del quartiere

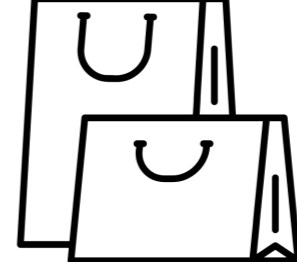

**Nuovi spazi commerciali
associativi/sociali**



Maggiore sicurezza

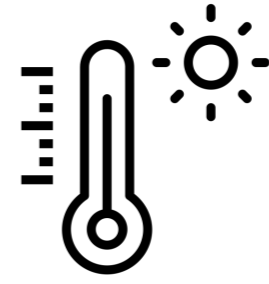
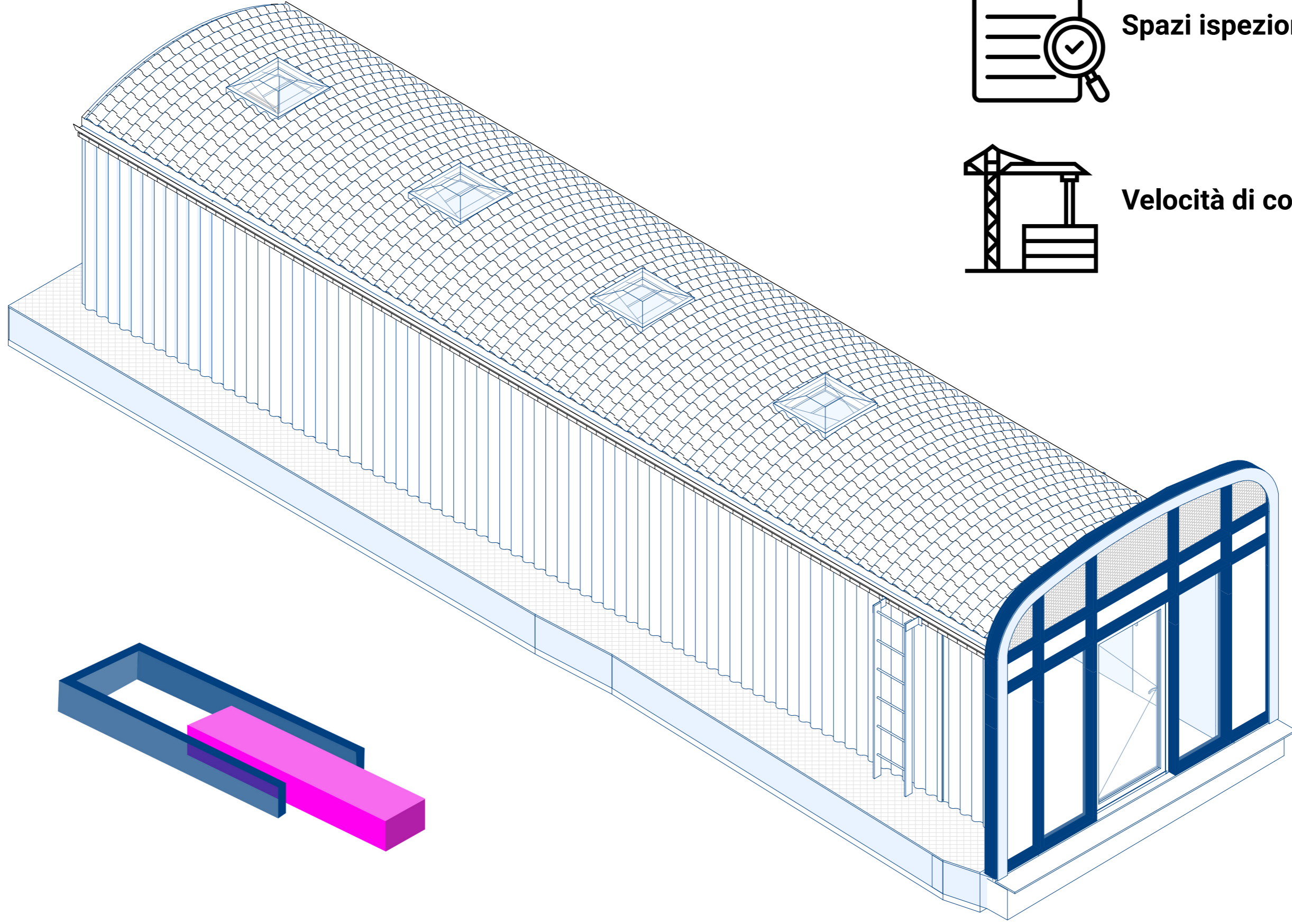

Comfort termoigrometrico



Spazi ispezionabili da RFI

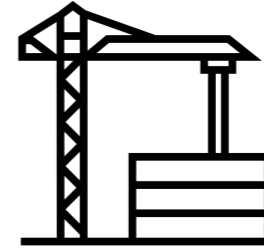

Velocità di costruzione



ICE
QUIN

ICE
QUIN

ICE
QUIN

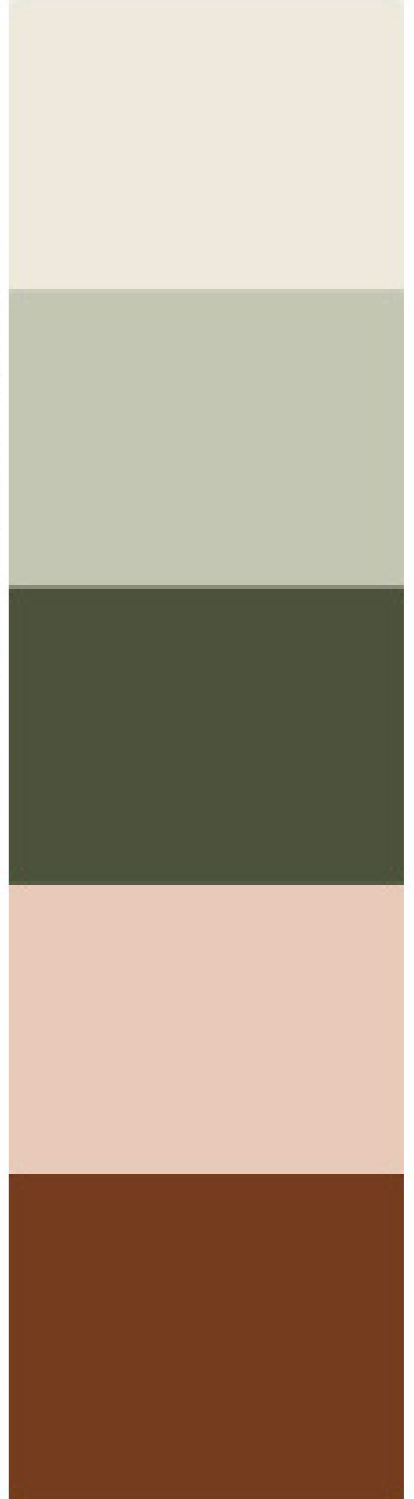
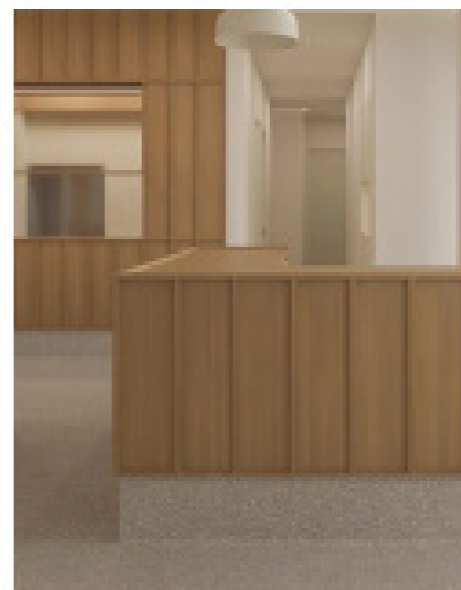
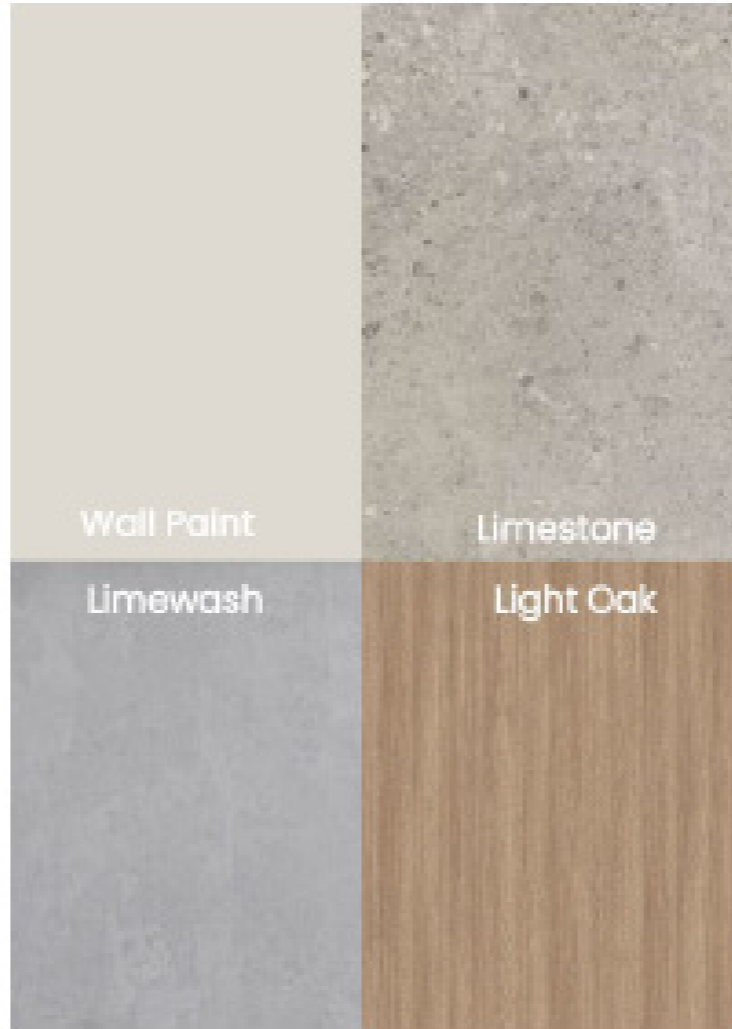
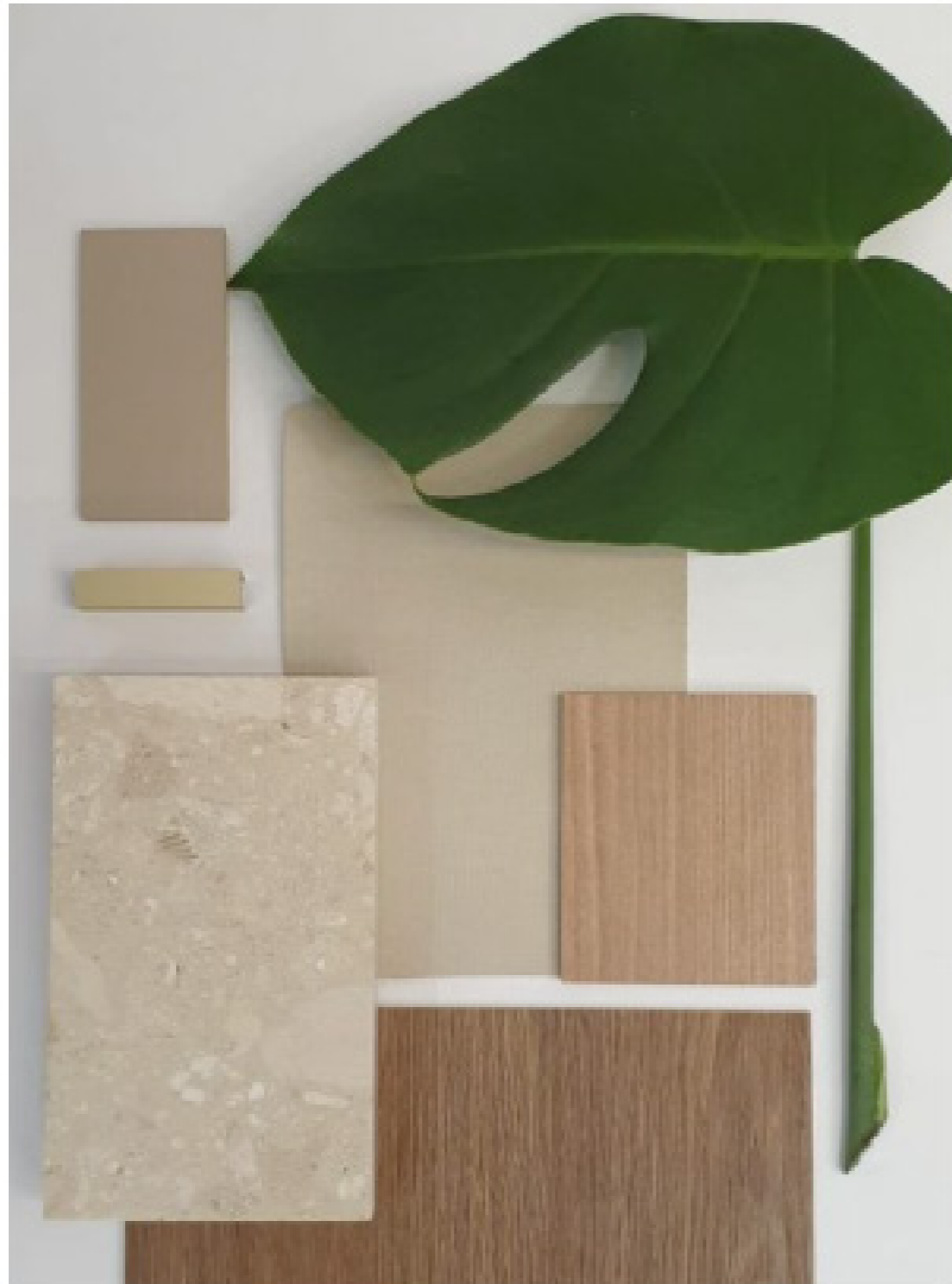







Riqualificazione Voltini Ferroviari di Via Buranello

PIANO NAZIONALE DI RIPRESA E RESILIENZA (P.N.R.R.)
MISSIONE 5 COMPONENTE 2 MISURA 2.2 - P.U.I